



Kurdistan Engineers Union

# Shear Walls in Reinforced Concrete Building

September-2013

**Falah Ali Abdul Husain**

**Civil Engineer**

**Baghdad University 1986**

**Keu ID: 7913**

## Introduction:

The primary purpose of all kinds of structural systems used in the building type of structures is to support gravity loads. The most common loads resulting from the effect of gravity are dead load, live load and snow load. Besides these vertical loads, buildings are also subjected to lateral loads caused by wind, blasting or earthquake. Lateral loads can develop high stresses, produce sway movement or cause vibration, it is very important for the structure to have sufficient strength against vertical loads together with adequate stiffness to resist lateral forces.

Reinforced concrete (RC) buildings often have vertical plate-like RC walls called Shear Walls (Figure) in addition to slabs, beams and columns. These walls generally start at foundation level and are continuous throughout the building height. Their thickness can be as low as 150mm, or as high as 400mm in high rise buildings. Shear walls are usually provided along both length and width of buildings (Figure 1). Shear walls are like vertically-oriented wide beams that carry earthquake loads downwards to the foundation.

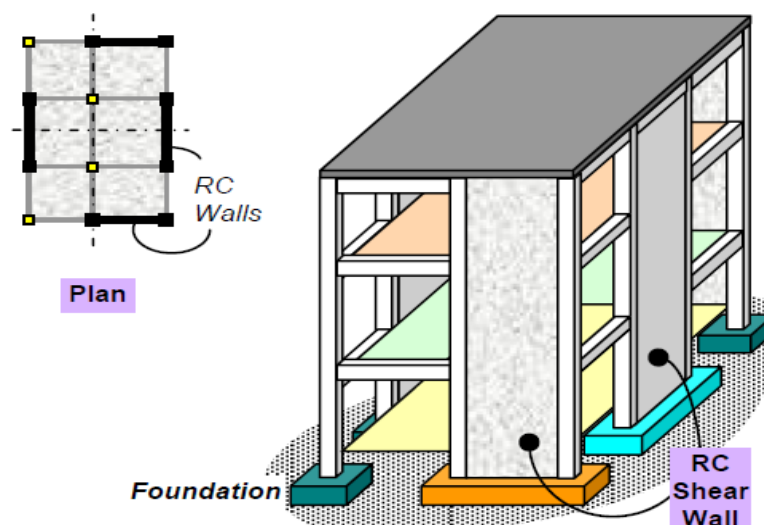

Building structures can be classified as:

1. Structural Frame Systems: The structural system consists of frames. Floor slabs, beams and columns are the basic elements of the structural system. Such frames can carry gravity loads while providing adequate stiffness,
2. Structural Wall Systems: In this type of structures, all the vertical members are made of structural walls, generally called shear walls,
3. Shear Wall–Frame Systems (Dual Systems): The system consists of reinforced concrete frames interacting with reinforced concrete shear walls.



1. Structural Frame System



2. Structural Wall System



3. Shear Wall–Frame System

## Difference between shear wall and load bearing wall:

A "load-bearing" wall is typically defined as a wall supporting any vertical load in addition to its own weight. A shear wall transfers lateral loads from a roof, ceiling or floor diaphragm to a foundation or other element. Although a shear wall might not carry gravity loads from roof or floor forces, it can still be considered load-bearing as the lateral forces induce a rotational, or overturning moment in-plane with the wall, which results in vertical reactions at the boundaries of the wall. These forces are in addition to the shear, or sliding forces induced in the wall

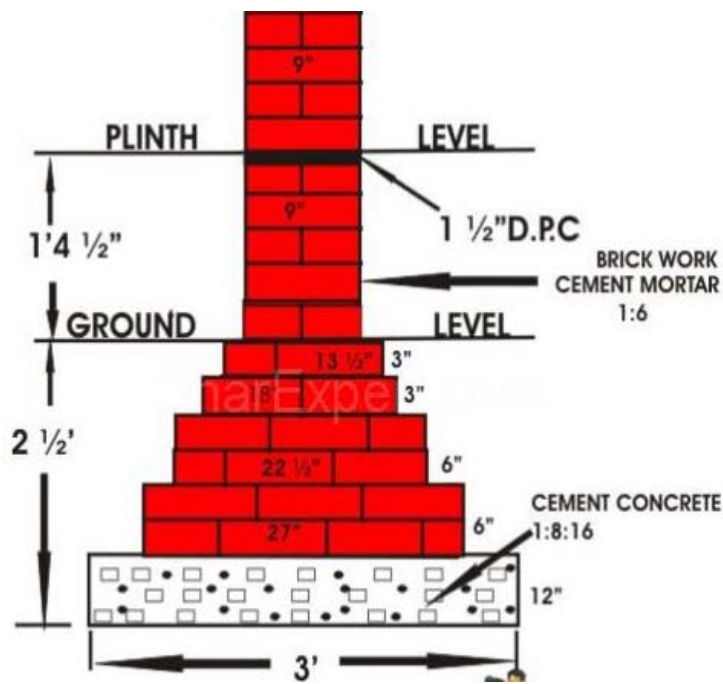

load-bearing wall



Shear Wall

## Geometrical shapes of Shear Walls:

Shear walls are oblong in cross-section, *i.e.*, one dimension of the cross-section is much larger than the other. While rectangular cross-section is common, Box shaped, L- and U-shaped and ...etc. sections are also used (Figure). Thin-walled hollow RC shafts around the elevator core of buildings also act as shear walls, and should be taken advantage of to resist earthquake forces.

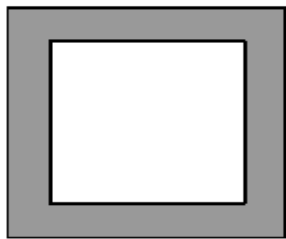

(a) Box Section

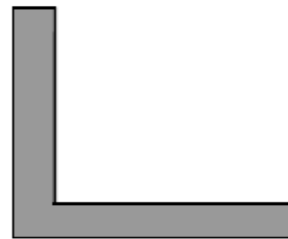

(b) L - Section

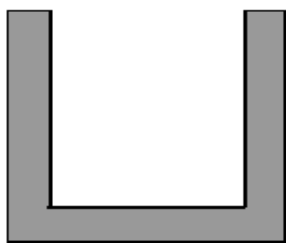

(c) U - Section

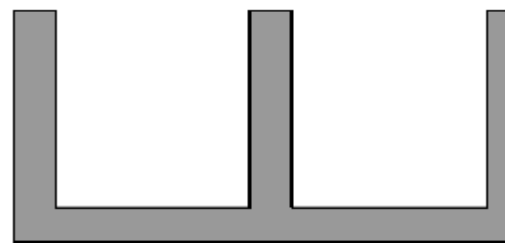

(d) W - Section

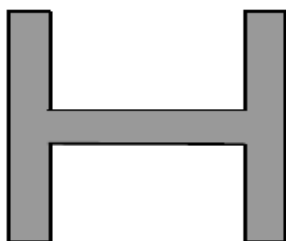

(e) H - Section

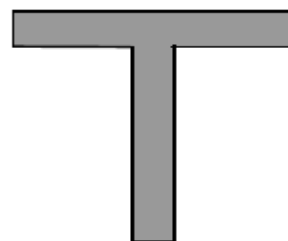

(f) T - Section

## *Advantages of Shear Walls in RC Buildings:*

Properly designed and detailed buildings with shear walls have shown *very good* performance in past earthquakes or lateral loads caused by wind. The overwhelming success of buildings with shear walls in resisting strong earthquakes is summarised in the quote: *“We cannot afford to build concrete buildings meant to resist severe earthquakes without shear walls.”* However, in past earthquakes, even buildings with sufficient amount of walls that were not specially detailed for seismic performance (but had enough well-distributed reinforcement) were saved from collapse. Shear wall buildings are a popular choice in many earthquake prone countries, like Chile, New Zealand and USA. Shear walls are easy to construct, because reinforcement detailing of walls is relatively straight-forward and therefore easily implemented at site. Shear walls are efficient, both in terms of construction cost and effectiveness in minimizing Earthquake damage in structural and non structural elements (like glass windows and building contents).



## Relation Between Strength And Stiffness For Concrete Shear Walls

A fundamental basis for the traditional method of design for earthquake-induced torsion is the assumption that the stiffnesses of the lateral load-resisting elements can be determined from the known dimensions of their cross sections, and that the strengths can then be assigned in proportion to these stiffnesses. It is true that the stiffness of a lateral load-resisting element made of a homogeneous material and strained only in the elastic range depends only on the gross section size of the element. However, the section sizes also determine the strength of the element, so if the strength is changed, the stiffness is also likely to change. Additional factors influence the stiffness and strength of a reinforced concrete element. These factors include axial load on the structure, the amount of steel and its distribution and the cracking of concrete under tension. The Canadian Standard Association, CSA A23.3-94, in its provisions for the design of reinforced concrete structures against earthquake-induced loads, recommends an effective moment of inertia,  $I_{eff}$ , equal to  $0.7I_g$  for columns and walls, where  $I_g$  is the gross moment of inertia of the section. Paulay and Priestley (1993) have suggested an effective moment of inertia for shear walls in the range of  $0.3 I_g$  and  $0.5 I_g$ , depending on the axial load. However, the actual stiffness may depart significantly from these suggested values.

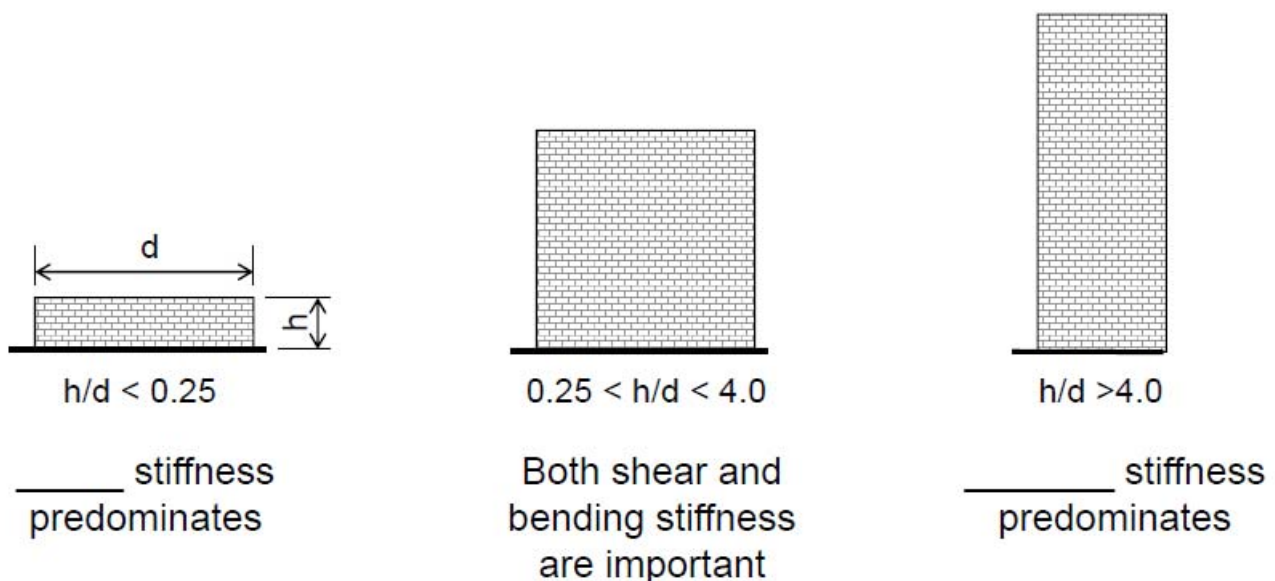

## Shear Wall Stiffness:

Deflection calculations shall be based on cracked section Properties.

Assumed properties shall not exceed half of gross section properties, unless a cracked-section analysis is performed.

### Cantilever wall

$$\Delta_{cant} = \frac{Et}{\left(\frac{h}{L}\right) \left[ 4 \left(\frac{h}{L}\right)^2 + 3 \right]}$$

h = height of wall

$A_v$  = shear area;  $5/6A$  for a rectangle

G = shear modulus; given as  $0.4E$  (1.8.2.2.2)

t = thickness of wall

L = length of wall

### Fixed wall (fixed against rotation at top)

$$\Delta_{fixed} = \frac{Et}{\left(\frac{h}{L}\right) \left[ \left(\frac{h}{L}\right)^2 + 3 \right]}$$

Real wall is probably between two cases; diaphragm provides some rotational restraint, but not full fixity.

---



## T- or L- Shaped Shear Walls:

Connection that transfers shear: (must be in running bond)

- Fifty percent of masonry units interlock
- Steel connectors at max 4ft.
- Intersecting bond beams at max 4 ft. Reinforcing of at least  $0.1\text{in}^2$  per foot of wall of wall

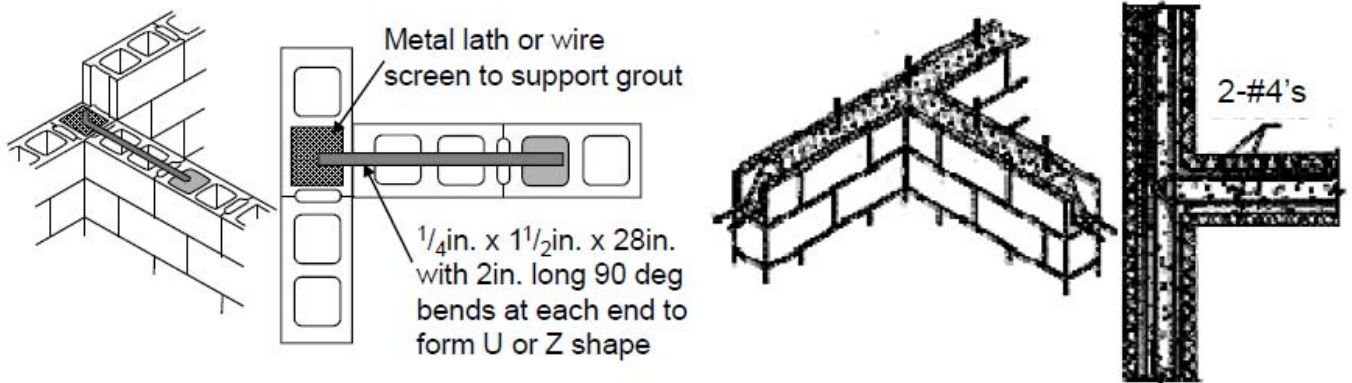

## Effective Flange Width:

Effective flange width on either side of web shall be smaller of actual flange width, distance to a movement joint, or:

- Flange in compression:  $6t$
- Flange in tension:
  - Unreinforced masonry:  $6t$
  - Reinforced masonry: 0.75 times floor-to-floor wall Height

## Analysis Methods:

When designing walls and plates loaded in their own plane three methods in determining internal stresses, moments and forces may be used:

1. Methods based on linear analysis,
2. Methods based on plastic analysis,
3. Methods based on non-linear material behavior.

### 1.Linear Analysis:

In the Finite element programs a linear analysis is performed for each static load case that is defined and it involves the solution of the system of linear equations represented by the equations and is solved in a single step:

$$Ku=r$$

Where K is the stiffness matrix, r is the vector of applied loads and u is the vector of resulting displacements. This is a simple mathematical approximation to simplify real time problems. Resulting in small deflections and rotations, stresses are proportional to strain and material is elastic.

## 2. Plastic Analysis:

The Plasticity theory in its simplest form deals with materials that can deform plastically under constant load when the load has reached a sufficiently high value. Materials with such ability are called perfectly plastic materials. The definition of a perfectly plastic material or rigid-plastic material is that no deformations occur in the material until the stresses reach the yield point and when that happens arbitrary large deformations can occur without any changes in the stresses. In the uniaxial case this corresponds to the stress-strain curve in Figure. This material does not exist in reality but it is possible to use this model when the plastic strains are much larger than the elastic strains.

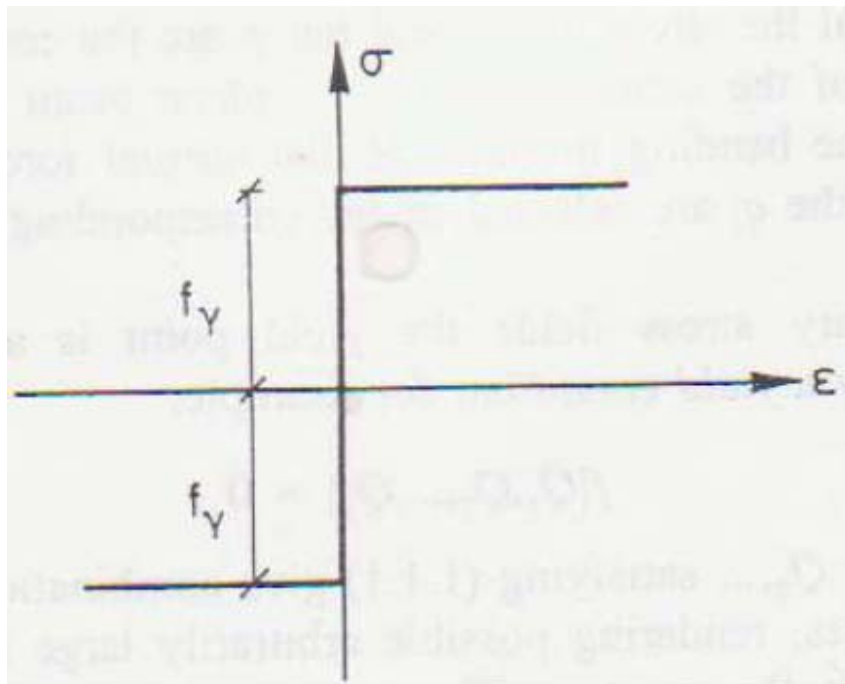

Uniaxial stress-strain relation for rigid-plastic material

### 3. Nonlinear Analysis:

In recent years nonlinear finite element models have been used to utilize the behavior of reinforced concrete. Many models have been proposed to describe this nonlinear behavior of a reinforced concrete by using nonlinear finite element analysis

.....

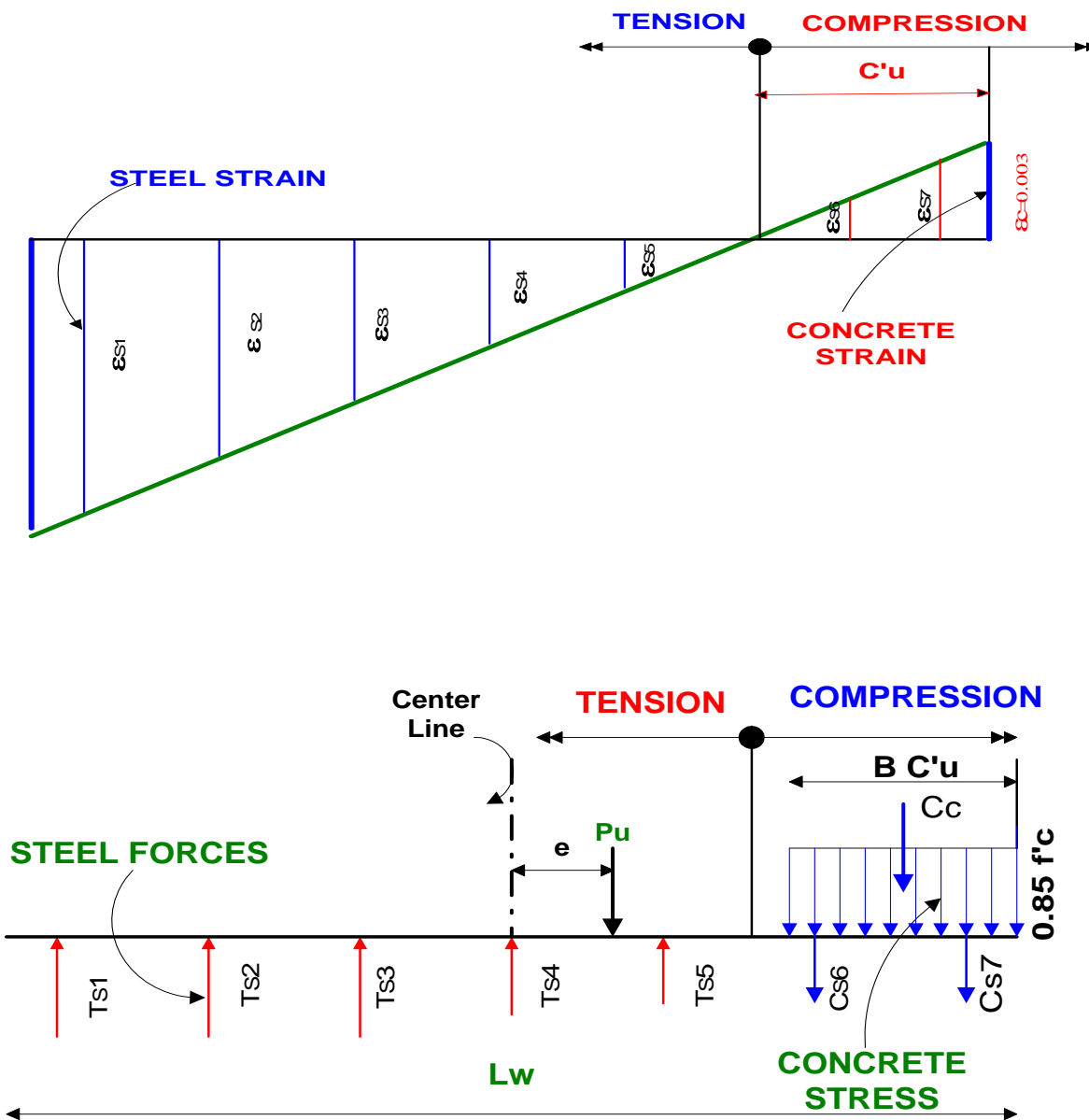

## *Structural Features*

The lateral and gravity load-resisting system consists of reinforced concrete walls and reinforced concrete slabs. Shear walls are the main vertical structural elements with a dual role of resisting both the gravity and lateral loads. Wall thickness varies from 140 mm to 500 mm, depending on the number of stories, building age, and thermal insulation requirements. In general, these walls are continuous throughout the building height; However, some walls are discontinued at the street front or basement level to allow for commercial or parking spaces. Usually the wall layout is symmetrical with respect to at least one axis of symmetry in the plan (Figure). Floor slabs are either cast-in-situ flat slabs, or, less often, precast hollow-core slabs. Slab thickness varies from 120 mm in the republics of the former Soviet Union, to 220 mm. Buildings are supported by concrete strip or mat foundations; the latter type is common for buildings with basements. Structural modifications are not very common in this type of construction. Reinforcement requirements are based on building code requirements specific for each country. In general, the wall reinforcement consists of two layers of distributed reinforcement (horizontal and vertical) throughout the wall length (Figure). In addition, vertical reinforcement bars are provided close to the door and window openings, as well as at the wall end zones (also known as boundary elements or barbell).

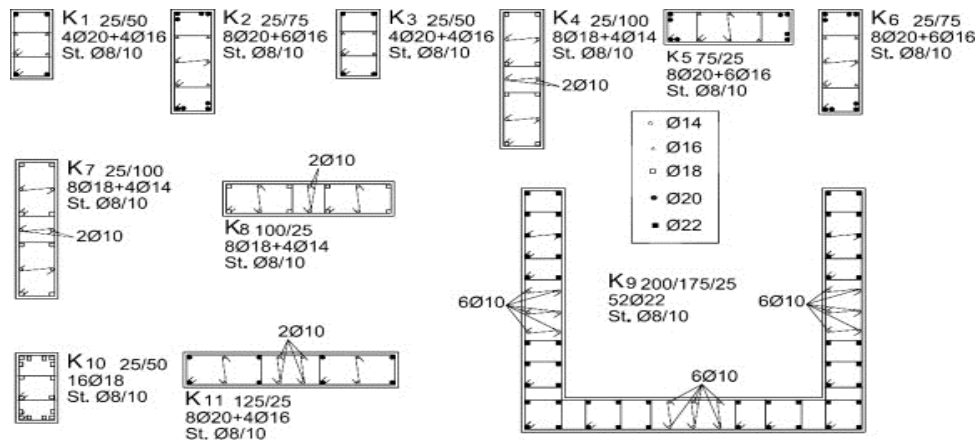
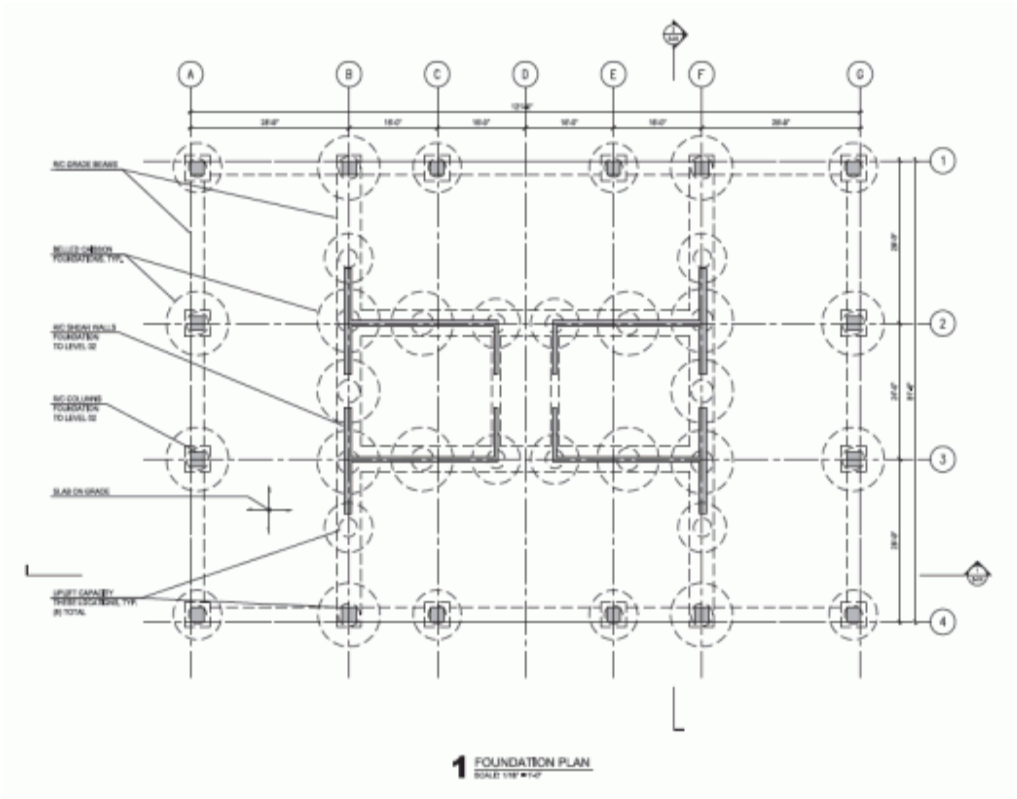

Construction of shear walls:







## References:

- Design Of Concrete Shear Wall Buildings For Earthquake Induced Torsion: J.L. Humar and S. Yavari
- Lateral Load Analysis Of Shear Wall-Frame Structures : Tolga Aki,S
- Concrete Shear Wall Design : Wira Tang, S.E
- Concrete Shear Wall Construction : M. Ofelia Moroni